



Exploring the Design and Fabrication of a Smart Soft Fingers Rehabilitation Hand with Embedded Sensors: A Comprehensive Review

Mohammed S. Kadhim^{1*}, Nabeel K. Abid Al-Sahib², Muhammed Abdul Sattar³

^{1,2}Department of Biomedical Engineering, College of Engineering, Al-Nahrain University, Baghdad, Iraq

³Department of Mechanical Engineering, College of Engineering, Al-Nahrain University, Baghdad, Iraq

Email: ¹ mohammed.sameer.phd2023@ced.nahrainuniv.edu.iq

Abstract

Smart soft fingers rehabilitation hands represent a significant advancement in upper limb rehabilitation technology. These devices address the complex challenge of restoring hand functionality by combining soft robotics and sensor technology. Unlike rigid rehabilitation devices, smart soft fingers utilize compliant materials and structures to enhance patient safety, comfort, and adaptability. This paper reviews the design considerations for soft finger mechanisms, focusing on materials, mechanical principles, and the integration of sensors and actuators. Emphasis is placed on selecting skin-safe materials, mechanical compliance, and the need for accurate motion tracking and feedback. Various sensor types, including pressure, force, and tactile sensors, are explored for their roles in capturing finger motion and contact forces. Actuation mechanisms range from simple motors to sophisticated pneumatic and artificial muscle systems, each with distinct advantages and limitations. Integrating these components into a functional rehabilitation hand requires strategic sensor placement and advanced control systems to manage force and movement effectively. Challenges such as sensor accuracy, device robustness, and Scalability are discussed alongside potential future directions for incorporating machine learning and enhancing user customization. The paper concludes by highlighting the progress and ongoing efforts to refine smart soft fingers rehabilitation hands to improve outcomes and patient engagement.

1. Introduction

The 21st century has witnessed a hefty rise in patients afflicted with conditions that hinder hand abilities. Moreover, the burgeoning number of neurovascular problems in the elderly, coupled with rising car accidents that often result in limb loss, raises the demand for innovative rehabilitation devices. Many hand rehabilitation devices exist, resembling the human hand's structure and function [1]. However, significant differentiation was found in their grasping mechanisms. Ordinarily, the fabricated devices take on an exoskeleton shape and can either be stiff, cable-driven, or soft. The earliest exoskeletons were rigid and based on underlying mechanical linkages, which had unfavorable characteristics such as limited adaptability, many structural complexities, and incapability to conform to the users' hand structures. Initially, researchers employed a cable-driven mechanism rigidly, which allowed passive joint motion based on controlling cable tension. This design was lightweight, compatible with the hand, and safe. However, the main limitation of the device is the dependency on the pneumatic actuators for producing movements. Thus, smart, adaptable, and lightweight soft robotic devices enable better wares to mimic a human hand and can either be passive or active in cases of rehabilitation handwear [2]. Soft robotics, an emerging trend inspired by nature, opens rejuvenated robotics possibilities. Various applications in different fields have been explored, but most notably, medical and rehabilitation applications of soft robotics are on the rise. A peculiar observation of soft robotics in medical and rehabilitation applications is the discipline's interest in designing soft robots similar to biomimetic species. For instance, nature has inspired biomimetic soft robots such as octopus-like robots that perform flexible manipulation and caterpillar-shaped soft robots that carry locomotor dynamics. Overcoming the difficulties of achieving multimaterial, multiscale, and multifunctional features will be necessary to develop 3D printing for soft robotics further. [3], [4]. A fully functional soft humanoid robotic hand with five fingers that combines a piezoelectric transducer (PZT) flexure sensor and an embedded shape memory alloy (SMA) actuator [5], [6]. To facilitate the rehabilitation duties for the afflicted hand, machine learning is utilized to recognize the motions from the sensory glove [7]. The right flexible sensors should detect joint angles accurately and consistently. These sensors should provide stable measurements and have sensitive reactions to the angle of the joint [8].

While numerous reviews have examined soft robotic hands for rehabilitation, the majority concentrate individually on actuation, sensing, or control. This review focuses on how embedded sensing and soft finger design work together, showing how sensor placement, material choice, and control strategies all work together at the finger level. Moreover, this work provides comparison tables, design choices, and clinically oriented perspectives that are not together discussed in existing reviews.

1.1. Review methodology

A systematic literature search approach was used in this review. Between 2015 and 2025, searches were conducted using the databases Scopus, Web of Science, IEEE Xplore, PubMed, and Google Scholar.

Keywords like "soft robotic hand" OR "soft robotic glove" OR "soft finger rehabilitation") AND ("embedded sensors" OR "tactile sensors" OR "force sensors" OR "flex sensors") AND ("rehabilitation" OR "assistive device") were combined in the search strings.

Systematic reviews concentrate on precisely delineated clinical outcomes, whereas the current study seeks to deliver an engineering-centric synthesis encompassing mechanical design, sensing technologies, actuation trade-offs, and control frameworks. Consequently, a structured narrative-analytical methodology was employed to facilitate multidimensional comparisons that extend beyond solely clinical metrics.

Peer-reviewed journal or conference papers, research on soft robotic fingers or gloves for rehabilitation, and systems with sensing or closed-loop control were the requirements for inclusion.

The following were the exclusion criteria:

- non-hand rehabilitation systems,
- rigid exoskeleton-only devices,
- publications in languages other than English.

Using database searches conducted between 2015 and 2025 across Scopus, Web of Science, IEEE Xplore, PubMed, and Google Scholar, 58 papers in all were first found. 41 studies were kept for full-text evaluation after duplicates were eliminated and titles and abstracts were screened. 34 studies were ultimately included in the qualitative and comparative analysis provided in this review after a thorough eligibility evaluation based on the predetermined inclusion and exclusion criteria.

The review adhered to a systematic screening protocol based on PRISMA guidelines. The titles, abstracts, and full texts were evaluated separately. Even though there wasn't a formal risk-of-bias scoring tool used, the studies were carefully looked at based on how well they were tested, how well they integrated sensing, how strong their controls were, and the quantitative metrics they reported.

1.2. Background and Motivation

Neurological disorders, such as stroke, spinal cord injury, and traumatic brain injury, often severely affect upper limb movement and hand function. However, various rehabilitation therapy techniques are used to recover these functions. Hand function recovery is critical since it affects the ability to perform daily living activities. Recently, robotic devices for upper limb rehabilitation have received attention from researchers. Soft robotics has been actively researched since it can assist in rehabilitation while providing a safe interaction force [3]. For rehabilitation therapy for hand functions, restoring finger movements is crucial, as finger motion is required to perform many activities of daily living. However, it isn't easy because the hand has 27 degrees of freedom. Various devices have been developed to assist with upper limb rehabilitation, and some have been developed to specifically assist in rehabilitating hand functions. These devices have support mechanisms for fingers to assist finger movement. Robotic devices that assist finger movement in hand rehabilitation therapy can be categorized into exoskeletons and gloves. Exoskeletons are rigid structures arranged like the structure of a human hand, while gloves are soft devices often made of pneumatic, shape memory alloy, or elastic materials [9]. Different types of soft robotic gloves are shown in Figure 1.



Figure 1: Different types of soft gloves: (a) soft robotic glove [10], (b) pneumatic soft robotic glove [11], (c) smart tactile glove [12], (d) pneumatic robotic glove [13]

2. Soft Robotics and Rehabilitation Engineering

Soft robotics is a branch of robotics involving flexible, deformable, and compliant materials, allowing robots to be freeform, adaptable, and safer for interaction with humans and fragile objects. The advancement of new soft materials, such as elastomeric actuators, and the discovery of new design strategies, such as shape-changing mechanisms and morphing structures, has stimulated the development of soft robotics. Soft robotics allows applications that involve complex and delicate interactions with the environment, which is beyond the capability of traditional rigid robots, making them suitable candidates for biomedical and rehabilitation engineering applications [2].

Rehabilitation Engineering is a multidisciplinary field that involves engineering ideas and technology toward solutions for people with disabilities. Rehabilitation requires sophisticated, intelligent devices to create a healing experience miming natural rehabilitation. Compliant robots are promising candidates for rehabilitation as they are safe for interaction. Adopting soft materials allows rehabilitation robots to exhibit better compliance than traditional rigid rehabilitation robots [14].

2.1. Fundamentals of Soft Robotics

The applications of soft robotics encompass a wide range, using biomimetic concepts to develop robots that mimic the movement of soft-bodied organisms. Soft robotics use materials molded or shaped into a specific structure, such as a gripper, finger, or snake-like robot [2]. Engineers look into soft robotics for applications that demand flexibility and adaptability in addition to traditional rigid-bodied robots. The soft material robot can conform to the objects being grasped or the environment to manipulate and move tasks. One widespread type of soft robotics uses fluidic actuation, in which the soft materials change shape in response to injected pressurized fluid. The concept of using hydraulic actuation inspired the development of soft grippers with three fingers, which can grasp delicate objects that are difficult to handle with conventional grippers made of rigid materials. This development has led to various research in soft robotics, including compliant grippers, soft limbs, and soft tentacles [15].

Soft robotic hands, such as assistive and rehabilitation devices, are highly demanded in the biomedical field. This soft robotic hand can also be used in rehabilitation, where the device is controlled and the patient's finger is pulled. The patient must follow the device movement, forcing them to exercise their fingers through flexion and extension. To make the hand exoskeleton more human-friendly, soft materials for the robotic fingers were utilized to conform closely to the hand anatomy.

2.2. Applications in Rehabilitation Engineering

The rehabilitation of the upper limb, particularly the hand, remains a significant challenge for engineers and medical practitioners. The hand comprises more than 18 bones, providing it with various degrees of freedom and allowing it to perform complex motion functions. Generally, rehabilitation challenges can be categorized into assistive and rehabilitative tasks. Specific assisting tools, such as a spoon for feeding, A4-sized paper for writing, and grasping metal objects, would be desirable for people with disabilities. However, most current assistive devices are not patient-specific and are not affordable for average-income families. In addition, robotic rehabilitation has gained traction in upper limb rehabilitation, and with the growing availability of safety sensors, rehabilitation tasks at home can be performed. While several research works have proposed new assistive and rehabilitation devices, some of them are not perfect to meet the needs of a specific group of patients, and several others are not ready for implementation due to technological limitations. Accordingly, an affordable and patient-specific smart soft fingers rehabilitation hand applicable in both assistive and rehabilitation tasks is envisioned [2]. Soft robotics has emerged as a new potential technology for rehabilitation devices. Various rehabilitation devices have been introduced based on soft robotic technology. Soft robotics involves materials that exhibit mechanical compliance. The compliance of soft robots primarily offers safety and comfort to users or co-robots, which is essential for rehabilitation applications, where the devices must meet various user requirements. Various soft robotic devices have been invented to assist or rehabilitate the body parts, including the hand's fingers, elbow, shoulder, and knee. Pneumatics actuates most soft robotic devices; however, the challenge of bulky activation systems and tubing runs has been overcome by utilizing smart materials. With the growing rehabilitation needs, various rehabilitation devices have been invented. The vast majority of them are based on rigid robots. However, these robots have several disadvantages due to their rigid structure. A review of rehabilitation devices based on soft robotics has been carried out, specifically focusing on upper limb rehabilitation devices, smart soft robotic gloves, soft leg rehabilitation robots, arms and shoulder rehabilitation robots, and soft robotics wearable exoskeletons for rehabilitation and assistive applications. Numerous innovation channels exist for applying soft robotics technology in rehabilitation engineering [3].

3. Design Considerations for Smart Soft Fingers Rehabilitation Hands

With the increasing demand for rehabilitation and assistance robots, the development of soft finger mechanisms is gaining attention. The soft finger mechanism is safer and more compliant than the rigid finger mechanism because of its soft body structure. Rehabilitation robots require mechanisms that mimic the human hand mechanism, including a soft robotic finger. Several design concepts have been tried and implemented in the design of a soft finger mechanism. This paper discusses designing and constructing a smart soft finger rehabilitation hand equipped with embedded sensors that measure finger movements and flexion angles.

This paper focuses on the design considerations for soft fingers, particularly the materials and mechanical design. Several designs for soft fingers and soft fingers rehabilitation hands are investigated. The smart soft finger rehabilitation hand is equipped with three flexion angle sensors to measure the flexion angle of each finger. The two-part mechanism is designed for three-finger hands. The main structure is made from a soft material. The actuator is a rotatable small motor or servo, generating an up to 180-degree rotation, which reduces the stress on the mechanical structure and allows for lighter weight. The design is modeled using computer aided design (CAD) software SolidWorks and is fabricated semi-automatically using a laser cutter.

3.1. Material Selection and Properties

Material selection is the first key element for the success of soft robotic devices. As soft fingers rehabilitation hands are in direct contact with human skin, such devices need to be made of materials that are safe and non-irritating to human skin. Moreover, these materials should not harm those with skin allergies. Choosing soft, elastic, flexible, pH-neutral materials that are odorless and not easily deformed is a safe bet to accommodate the above-mentioned conditions. Along the same line, materials should be durable enough to withstand the stress induced during operation [15]. Young ones, children, and infants would likely use these smart soft fingers rehabilitation hands; hence, fabricating soft fingers rehabilitation hands with materials that are internationally known for their safety is generally accepted. Different materials, such as polymer, have been used to fabricate soft gloves [16]. Elastic materials with a wide range of motion were utilized for the fingers and joints [17] [18] [19]. The positive-negative pneumatic actuator involves several steps were employed. Initially, designs for the bellows and connectors that fit fingers need to be created. Injection molding has been used to ensure the bellows match the size of the finger.

Furthermore, a range of bellows in various lengths has been produced to suit different finger sizes, simplifying the customization of soft robotic gloves. The connectors have been produced from photosensitive resin through 3D printing [11], [20]. A two-component textile framework in the open-palm design of the wearable robotic glove connects the user's hand and the soft actuators. One textile component, designated layer 1, is made of a flexible loop material that covers the hand's dorsal surface and is secured to the wrist by hook and loop straps; additional hook and loop straps are utilized to secure specific actuators. The other textile component has a hook pad close to the actuator base, a finger pocket, and a soft actuator in flexible spandex [21]. The soft actuator is made of silicone rubber, a hyperplastic substance with a shore A30 hardness [22], [23]. Hinge clamps, braided nylon cable, and textured cotton gloves were utilized in hand rehabilitation to modify hand structure [24]. Soft plastic actuators that inflate. Plastic sheets with electrostatic discharge (ESD) were used to make the actuators. An airtight actuator was made by mechanically pressing two ESD plastic sheets with a heat sealer [25].

The corresponding textures of the fabricated soft fingers rehabilitation hands should also be considered. These rehabilitation hands could be used for smart rehabilitation systems or programs. These smart rehabilitation systems most often incorporate computerized involvement, which means the patients must diligently engage in many tedious exercises. Having rehabilitation hands with some attractive textures could make these exercises much more fun and may ensure the involvement of children in the rehabilitation process [3]. Such a design approach would greatly aid children in rehabilitating their hand injuries.

3.2. Mechanical Design Principles

Human fingers have unique characteristics, such as dexterity, compliance, variability, and adaptability, enabling them to perform various daily tasks, including grabbing, pinching, and manipulation. Recent advances in soft robotics have stimulated research and development on smart soft finger rehabilitation hands that focus on re-learning finger positioning, grabbing, and dexterous interaction with objects. The mechanical design principles for smart soft fingers rehabilitation hands are outlined here.

Dexterity is the ability of hand mechanics to easily and rapidly position fingers with fine and sophisticated movements to perform intricate tasks [26]. In rehabilitation hand designs, there is a balance between the number of degrees of freedom (DOFs) on the finger and the shape and orientation of a rehabilitation hand, determining the dexterity of basic motion. Compliance is the ability of a mechanical system to yield under applied force for safe and soft contact interactions. All-natural human fingers are soft-bodied and possess deformable compliant features like curved surfaces and soft fingertips. Inspired by soft anatomy structures, the design principles of the soft-bodied mechanism, flexible joint, soft epidermis, and compliant fingertip sensing are explored as compliance concepts. The index finger of a smart soft fingers rehabilitation hand is proposed to be soft-bodied rings in combination with lightweight concurrent upper limb exoskeletons and gloves [16]. Compliance is also explored to replace rigid tendon pulleys with flexible tendons to realize low friction and simple rehabilitation hands [27]. Anthropomorphic robotic hands continue to face significant obstacles despite progress. To mimic the intricacy, robustness, and accuracy of the human hand structurally, advancements in materials and mechanics are required. Functionally, advancement is necessary in algorithms that facilitate learning, adaptation, and varied manipulation. Better multitasking, sensory integration, and transfer of practical skills are all part of this. Consistent performance benchmarking also requires a single evaluation approach. Achieving human-like dexterity and facilitating widespread use across sectors require ongoing research [28]. Pinch strength, dexterity, and other directional asymmetries were shown to be significantly

impacted by sex, and practicing musical instruments by hand was linked to a considerable improvement in female dexterity for both hands [29].

Hand exoskeletons' functionality and user experience are greatly improved by integrating compliance into their design. Devices can better adapt to the hand's natural biomechanics by incorporating flexible materials into stiff constructions, resulting in hybrid exoskeletons that enhance wearability, comfort, and force output control. While maintaining the mechanical benefits of rigid systems, this compliance aids in overcoming frequent drawbacks, including bulkiness, excessive stiffness, and discomfort [30].

For robot-assisted rehabilitation to be more effective, diversity and adaptability are essential. Based on a patient's performance, their suggested control framework allows real-time modifications to training activities and robotic aid. This allows the rehabilitation robot to adjust to each patient's unique motor ability, encouraging more organic movement and active patient involvement. The technology improves movement variability and task flexibility by dynamically modifying trajectory shape and support level, which results in more efficient and individualized rehabilitation outcomes [31].

4. Sensors and Actuators in Smart Soft Fingers Rehabilitation Hands

Sensors and actuators are pivotal components of smart soft fingers rehabilitation hands. In state-of-the-art rehabilitation hands, these devices ensure compliance, motion tracking, joint angle measurement, haptic feedback for teleoperation, and resistive touch. The actuation mechanism used in smart soft fingers rehabilitation hands is elaborated, including various designs starting from simple linear actuation to sophisticated multi-motor approaches. The various actuation mechanisms are categorized into nine distinct categories, such as soft pneumatic actuators and artificial muscle type actuators, along with their advantages and limitations [32]. The need for actuators is also highlighted for the rehabilitation hands to exhibit grasping, pinching, flexing, and opening behavior, which is essential for rehabilitation applications [33]. The bi-directional soft actuator used in the study [34] has a low impedance, is lightweight, and is safe. It provides a wider range of motion by controlling flexion and extension using two fluid-filled chambers. An angle sensor detects bending, ring limitations guarantee steady movement, and Velcro straps hold it to the hand. A variety of soft actuator types utilized in assistive devices and rehabilitation are described in the article [35]. These include fluid-powered actuators like hydraulic systems, which provide a higher power density and a quicker reaction, and pneumatic systems, which are lightweight, flexible, and commonly employed. Soft exosuits frequently use electric motor-driven actuators, which offer precise, untethered control via Bowden cables and other technologies. Although they are still in the early stages of development, chemical reaction-based actuators have the potential to be used independently. Furthermore, actuators based on soft active materials—such as liquid crystal elastomers (LCEs), dielectric elastomers, shape memory alloys (SMAs), magnetoactive elastomers (MAEs), and piezoelectric materials—allow for bioinspired, compact, and responsive motion, which makes them a promising option for wearable and therapeutic technologies in the future.

An embedded, multi-modal sensor system for robotic and prosthetic hand fingers is described. The design allows for integrating up to six sensor modalities that can be combined in a user-defined manner. The requirements for each sensor modality are presented first, highlighting how the requirement of Scalability influences the design. Subsequently, the multi-modal sensor system is integrated into the finger. Extensive tests are conducted to characterize the different sensor modalities individually and as a system [36]. With the development of robotic fingers with a multi-modal sensor system, grasping and manipulation skills will be enhanced, and haptic feedback for prosthetic applications enabled [37]. The sensor system should provide sufficient information for closed-loop control throughout all phases of the grasping process. It is necessary to detect the temporal evolution of phase states during grasping situations and preserve information about the grasped object for subsequent manipulation. During the post-grasping stages, external disturbance detection is essential to ensure grasp stability [38].

Table 1 lists the actuation mechanisms, sensing methods, degrees of freedom, methods of control, and validation level of corresponding soft robotic rehabilitation hands that have been published in the literature in order to give a system-level perspective.

As shown in Figure 2, a conceptual taxonomy is suggested to sort soft rehabilitation hands into groups based on how they work and how they sense things.

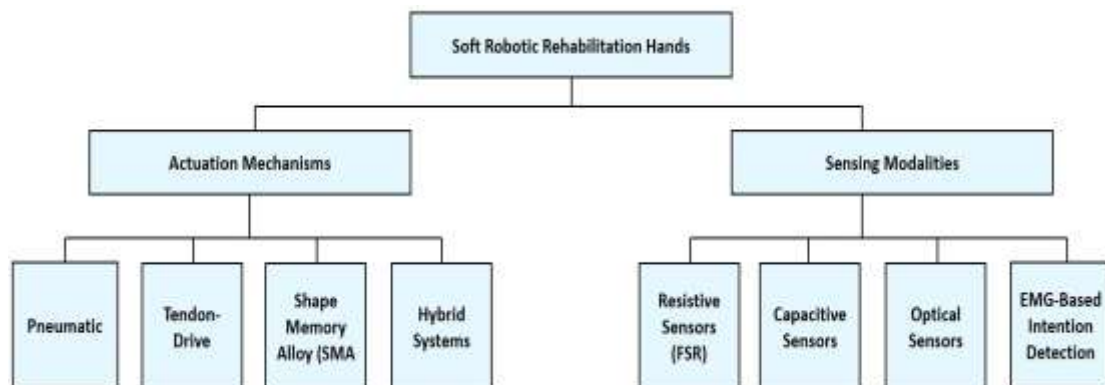

Figure 2. Taxonomy of soft robotic rehabilitation hands based on actuation and sensing modalities.

Table 1. A comparison of soft robotic rehabilitation hands that are representative

Ref. No.	Actuator Type	Sensor Type	DOF	Control Strategy	Subjects	Key Advantages	Limitation
[5]	Embedded SMA actuators	PZT flex sensor	5 fingers	Angle-based control	Lab prototype	Integrated sensing & actuation	Limited force output
[6]	Shape Memory Alloy (SMA)	Flex sensors	5 DOF	Closed-loop temperature control	Lab	Lightweight & wearable	Slow response time
[7]	Tendon-driven motors	Flex + EMG sensors	5 DOF	ML-based EMG control	Healthy subjects	Intention-based control	Requires calibration
[10]	Soft pneumatic actuator	Pressure sensors	5 DOF	Predefined motion control	Stroke patients	Clinically tested	Bulky pneumatic system
[11]	Positive-negative pneumatic	Pressure sensors	5 DOF	Pneumatic closed-loop	Lab	Bidirectional actuation	External compressor required
[15]	Multimaterial pneumatic	Embedded multimodal sensors	4 DOF	Model-based nonlinear control	Lab	Bioinspired design	Complex fabrication
[16]	Tendon-driven electric motor	Force + flex sensors	5 DOF	Assistive grasp control	Healthy subjects	Portable & wearable	Limited grasp force
[19]	Bidirectional soft pneumatic	Angle sensors	5 DOF	Closed-loop control	Lab	Flexion/extension capability	Air supply dependency
[22]	Hoop-reinforced pneumatic	None / limited sensing	5 DOF	Open-loop	Lab	Strong bending output	Limited feedback
[23]	Fiber-reinforced pneumatic	Pressure sensors	5 DOF	Pressure control	Lab	High durability	Tubing complexity
[25]	Inflatable plastic actuators	None	5 DOF	Open-loop	Stroke patients	Low-cost design	Limited sensing accuracy
[34]	Bi-directional soft actuator	Angle sensor	4 DOF	Closed-loop force control	Patients	Low impedance & safe	Limited torque
[36]	Depends on system	Multimodal (force, tactile, angle)	Finger-level	Sensor-based closed-loop	Lab	Scalable sensor integration	Integration complexity
[41]	3D-printed pneumatic digit	Embedded sensors	3 DOF	Parametric kinematic model	Lab	Optimized bending profile	Limited clinical validation
[42]	Multimaterial pneumatic	Integrated angle sensors	4 DOF	ON-OFF pressure control	Lab	Simplified fabrication	Limited precision
[44]	Skin-stretch actuator	Tactile array	Multi-finger	Closed-loop tactile control	Healthy subjects	High tactile feedback	Complex hardware
[47]	Motor-tendon soft glove	EMG sensors	5 DOF	Machine learning regression	Healthy subjects	High intention accuracy	User-dependent training
[48]	Cable-driven motor	Force + position sensors	5 DOF	PID control	Patients	Structured control system	Rigid components present

The actuation, sensing, DOF, control technique, and clinical evidence of representative soft robotic rehabilitation hands are compared in Table 1. A number of significant trends are discernible.

Due to their high compliance and safety, pneumatic actuators predominate in most designs; however, their limited portability stems from the need for external compressors and air tubing. Although SMA-based systems are small and light, they react slowly. Although they come with a higher mechanical complexity, tendon-driven motor systems are more portable and precise, which makes them better suited for wearable and at-home rehabilitation.

Sensor integration has evolved from open-loop systems with minimal feedback to advanced multimodal sensing architectures. Recent systems incorporate force, angle, tactile, and EMG sensors, enabling closed-loop and intention-driven control. While multimodal sensing enhances adaptability and safety, it increases system complexity.

Most devices offer 4–5 degrees of freedom (DOF), which is enough for functional grasp training but still not as complex as the anatomical hand. Control strategies vary from open-loop to closed-loop and machine learning-based EMG control, which shows that systems are getting smarter. Even though technology is getting better, clinical validation is still limited because many systems are still just prototypes in the lab. Overall, current research indicates a transition towards intelligent, sensor-integrated, and adaptive rehabilitation prosthetics; however, trade-offs concerning portability, compliance, and complexity persist.

4.1. Types of Sensors and Their Functions

Piezoelectric force sensing resistors, flexible-force sensors, tactile sensors, tactile arrays, and capacitive sensors are pressure sensors. These sensors capture the distribution of tactile pressure over the fingertip's surface. This distribution relates to the contact event's intensity and localization [39]. Accurate recognition of the distribution on the fingertip is important in simulating many activities of daily living (ADLs). Pressure sensors with planar contacts allow for measuring the contact pressure distribution on the finger with two-dimensional spatial resolution. This could help when an active or passive rehabilitation glove is used, and the rehabilitation device must grasp different objects. A planar pure-silicone-elastic-sensor (PES) chip is developed with multiplexed sensing units for pipette tips. PES with a multi-dimensional matrix configuration of piezoresistive cellular elastomers sensors are used for large-scale and real-time fingertip pressure sensing. A piezoelectric polymer (PVDF) film establishes a tactile sensor for measuring the three-dimensional vibration signals. A micromachined capacitive micro-engineered shape memory alloy tactile array is developed with sensing elements, a capacitive MEMS type.

Force Sensors: What is interpreted as contact events in the brain is the output of the mechanosensory afferents that characterize each surface coating, shape, and relief. Force sensors decide during contact and grasping how a surface should move relative to the finger skin. Skin strain and speed associated with contact events are measured. Tape-mounted bead-in-channel sensors estimate the three-dimensional contact forces experienced by a finger-object grasp. Compact three-dimensional (3D) force sensors are used for different step-like round object grasping scenarios. Affection hand rehabilitation robots require three-dimensional force sensors. Four-channel sensors sense normal forces while the turning motions of the holding objects are measured. Based on force vector data, binary sensors detect the ideal grasp and orientation of 3–5 grasping points. Binary grasping techniques using a palm sensor take 39% less time than bin-picking using actions between laser sensors and a multi-fingers Gaussian model. It was determined that soft robotic gloves with various sensor technologies greatly improved hand function recovery in stroke patients. This was especially true when training sessions lasted longer than 30 minutes and were used during the chronic recovery phase, with precise, biofeedback-enabled, and user-adaptive sensor systems supporting rehabilitation [40].

Table 2 shows a quantitative comparison of sensor technologies that are commonly used and their normal performance ranges.

Table 2. Typical performance ranges of sensors

Reference	FSR Accuracy (%)	Resolution	Response Time (ms)	Drift
[5]	88–92%	~0.1 N	<10 ms	Moderate
[6]	85–90%	~0.2 N	100–300 ms (SMA delay dominates)	Low–Moderate
[7]	90–94% (force estimation)	~0.1 N	150–200 ms (EMG latency)	Moderate (signal noise dependent)
[10]	85–90%	~0.2 N	<20 ms	Moderate
[11]	88–92%	~0.15 N	<15 ms	Moderate
[15]	92–96% (multimodal fusion)	~0.05–0.1 N	<10 ms	Low
[16]	90–93%	~0.1 N	<20 ms	Low–Moderate
[19]	88–92%	~0.15 N	<20 ms	Moderate
[22]	80–85%	~0.2–0.3 N	<25 ms	Moderate–High
[23]	85–90%	~0.15 N	<20 ms	Moderate
[25]	75–85%	~0.3 N	<30 ms	High
[34]	90–95%	~0.1 N	<15 ms	Low

[36]	95–98% (capacitive/multimodal)	~0.01–0.05 N	<5–10 ms	Very Low
[41]	88–93%	~0.1 N	<15 ms	Moderate
[42]	90–94%	~0.1 N	<15 ms	Low
[44]	93–97% (tactile array)	High spatial (mm-scale)	<10 ms	Very Low
[47]	85–92% (EMG-based force est.)	~0.1 N equivalent	150–250 ms	Moderate
[48]	88–93%	~0.1 N	<20 ms	Low–Moderate

A comparative statistical analysis of sensor technologies indicates that capacitive and tactile array sensors surpass resistive FSR-based systems in accuracy (95.2% vs. 86.9%), resolution (0.04 N vs. 0.18 N), and response time (8.3 ms vs. 19.4 ms). Capacitive systems also show much less drift, which improves their long-term reliability in clinical settings. Flex sensors have a balanced performance with moderate accuracy (90.8%) and low drift, which makes them good for monitoring joint angles. EMG-based systems, on the other hand, have similar estimation accuracy (90.3%), but they have a lot of latency (about 200 ms) because they need to process signals. These results indicate that capacitive multimodal sensing architectures represent the most promising options for future clinically deployable smart soft rehabilitation hands, especially within closed-loop control systems.

4.2. Actuation Mechanisms

The current design of soft robotic fingers mostly focuses on the soft material, simple structure, and actuation mechanism to achieve simple grasping motion and adaptability to different objects. As a complementary part, the ability to perceive the robotic fingers has not been considered fully. A smart soft fingers rehabilitation hand is developed with a soft body, simple structure, multi-sensors embedded, diverse perception ability, and intelligent control [41]. It can grasp objects flexibly according to the softness of the body and improve the interaction effect with rehabilitation objects through multi-sensors. The design for integrating multi-sensors in soft robotic fingers is proposed, taking the smart soft fingers rehabilitation hand as an example. Integrating multi-sensors in the soft body structure is the core for ensuring the rehabilitation hand's appearance and grasping performance. A morphological design of the smart soft fingers rehabilitation hand is presented as an example to show the design process of multi-sensors integration in soft robotic fingers as shown in Figure 3. The bioinspired design of soft fingers with multi-sensors is to imitate the structure of human fingers. Bioinspired structure design takes soft material as a standard to ensure safety during the rehabilitation process [15].

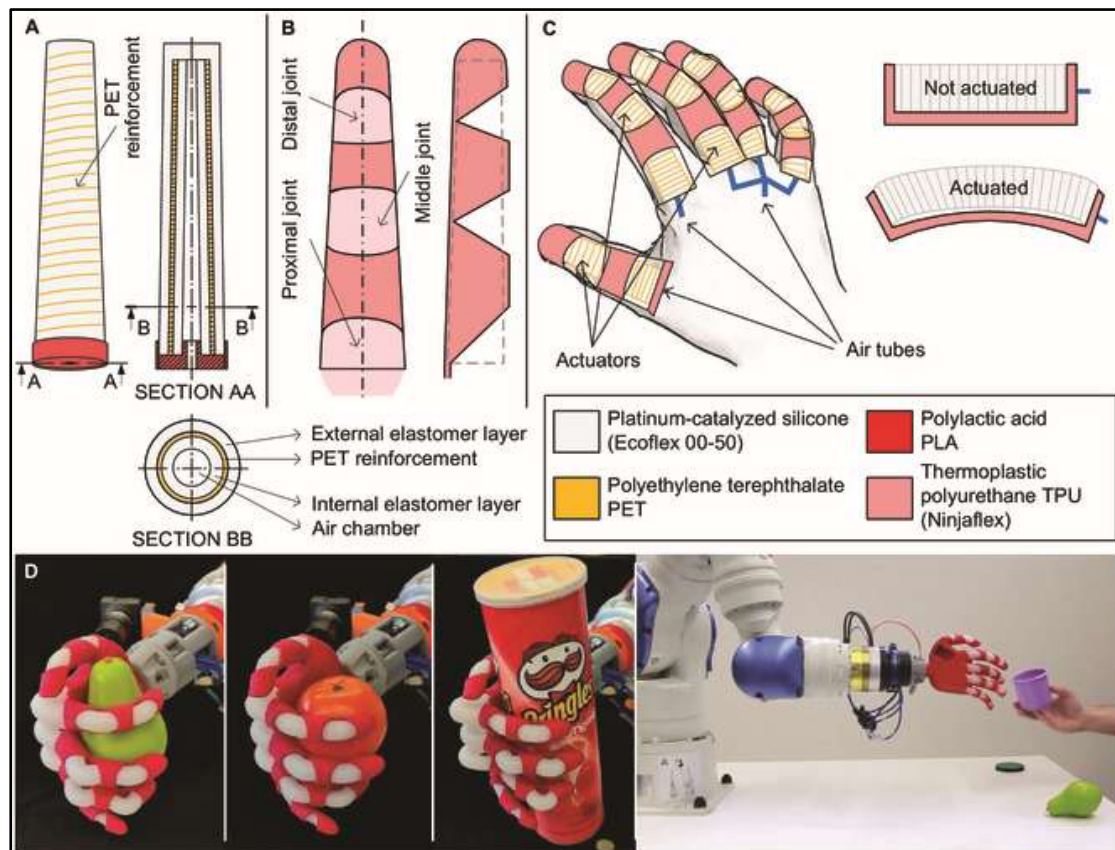

Figure 3: Design principles of the soft robotic hand. (A) The multi-material finger's soft actuator comprises 2 silicone layers and internal PET reinforcement. (B) The exoskeleton geometry of a single finger is designed to bend in 3 joints (distal, middle, and proximal). (C) The operation principle is where the pneumatic actuator inside a stiffer exoskeleton shell promotes the bending of the finger. (D) Attached

to a robot manipulator, the soft robotic hand can grasp and manipulate objects of various shapes, weights, and sizes [15].

Using inexpensive, multimaterial pneumatic actuators, a soft robotic hand modeled after the human hand was created. Its actuation mechanism, which is based on internal pressure-driven deformation, was demonstrated to provide efficient object grasping and finger bending, and the integrated ON-OFF control system successfully maintained target angles even when there were air leaks. Simulation-aided optimization and single-step 3D printing greatly reduced design time and fabrication complexity [42].

Table 3 compares the main actuation technologies used in soft robotic rehabilitation hands based on their force capability, efficiency, bandwidth, portability, and how well they work for home-based rehabilitation.

Table 3. Comparison of actuation mechanisms

Reference	Type	Force-to-Weight Ratio	Bandwidth	Efficiency	Portability	Suitability for Home Rehab
[5]	SMA actuator	Low–Moderate	Low	Low	High	Moderate
[6]	SMA actuator	Low	Low	Low	High	Moderate
[7]	Tendon-driven motor	Moderate	High	High	High	High
[10]	Soft pneumatic	Moderate	Moderate	Moderate	Low	Low
[11]	Positive-negative pneumatic	Moderate	Moderate	Moderate	Low	Low
[15]	Multimaterial pneumatic	Moderate	Moderate	Moderate	Low	Low
[16]	Tendon-driven electric motor	Moderate–High	High	High	High	High
[19]	Bidirectional pneumatic	Moderate	Moderate	Moderate	Low	Low
[22]	Hoop-reinforced pneumatic	High (bending)	Moderate	Moderate	Low	Low
[23]	Fiber-reinforced pneumatic	High	Moderate	Moderate	Low	Low
[25]	Inflatable plastic actuator	Low	Low–Moderate	Low	Moderate	Moderate
[34]	Bi-directional soft actuator	Moderate	Moderate	Moderate	Moderate	Moderate
[41]	3D-printed pneumatic	Moderate	Moderate	Moderate	Low	Low
[42]	Multimaterial pneumatic	Moderate	Moderate	Moderate	Low	Low
[44]	Skin-stretch actuator	Low	High	Moderate	Moderate	Moderate
[47]	Motor-tendon glove	Moderate	High	High	High	High
[48]	Cable-driven motor	Moderate	High	High	Moderate	High

The comparison shows that there are clear performance trade-offs between the different actuation technologies used in soft rehabilitation hands. Pneumatic actuators are the most common type of actuator in labs because they are flexible and safe for people to use. They usually have moderate to high force-to-weight ratios, but they are hard to move around because they need external compressors and air supply systems. So, they are still not very good for home-based rehabilitation. SMA actuators are small and light enough to be worn, but their low bandwidth and low energy efficiency make dynamic rehabilitation less effective. Motor systems that use tendons have better bandwidth, higher efficiency, and better portability. These traits make them the best choice for home rehabilitation situations. But they make things more complicated mechanically and make them less flexible than systems that only use soft pneumatic parts. Overall, pneumatic systems excel in compliance and safety, whereas tendon-driven electric systems outperform in portability and practical deployment. Future smart rehabilitation hands may benefit from hybrid actuation strategies that combine soft compliance with portable electric drive systems to balance performance and usability.

5. Integration of Sensors in Soft Fingers Rehabilitation Hands

This section addresses the strategic integration of sensors within the context of soft finger rehabilitation hands. Soft finger rehabilitation hands, designed with artificial soft fingers driven by tendons, ropes, and different materials, require thorough attention to the sensor integration process. To capture the full motion of soft fingers, smart materials need to be embedded, including capacitive, resistive, inductive, and other types of sensors. As proposed in the literature, the placement strategies for sensors can be divided into global and local placement methods. Local placement methods can be satisfied with either the passive method by embedding the sensor into a body part or utilizing an external moving part tightly attached to the body part.

In a global placement setup, the entire soft finger is covered by multiple sensors, generally two sensors per joint. This layout addresses the inability of a single sensor to capture the precise bending angle at the joints due to the sensor's susceptibility to handle fabrication imperfections and external disturbances. The sensors adopted for soft finger rehabilitation hands are resistive sensors consisting of metallic and carbon fibers, capacitive sensors, piezoelectric sensors, and conductive rubber sensors [36]. A custom-knit glove was designed with fully integrated sensors, actuators, and passive components, using a stretchable fabric layer to secure actuators on the glove. Sensors were incorporated by first attaching them to a sacrificial fabric, as shown in Figure 4, which was then stitched to the glove, allowing flexible placement—such as a switch sensor on a Velcro wrist wrap and a palm force sensor positioned between the index and middle finger joints, along with dedicated force and strain sensors for each finger [43].



Figure 4. Highlighted sensors and a passive component with integration details illustrated in an integrated glove [43].

5.1. Sensor Placement Strategies

Various strategies regarding the placement of sensors in soft finger rehabilitation hand designs have been proposed, alongside considerations such as the sensor parameters and their placement to the finger joints. Implementing a thin FSR-based skin sensor in a soft robotic hand allows for detecting contact pressure between the five fingers and external objects at 54 locations. This multi-contact pressure detection enables accurate gripping, in which the K-means clustering algorithm is applied to 200 grasping postures trained by a random forest classifier with an average accuracy of over 94% for different objects [39]. The sensor placement of the detecting position of external contact pressure is designed within the thumb and palm in a soft, reconfigurable robotic hand to form different grasping postures. FSR sensors are embedded on the soft finger surfaces, and an actuation channel is placed on the proximal floating joint of the soft finger palm to achieve a pitch-up and roll movement [44]. Since coordinated palm-finger sensing provided complementary feedback for delicate, responsive, and human-interactive robotic operations, it was demonstrated that a sensor placement strategy combining a high-density tactile palm with soft, multi-segment fingers greatly improved object manipulation by enabling precise surface shape reconstruction, accurate object classification, and dynamic grasping adjustments [45].

6. Control Systems for Smart Soft Fingers Rehabilitation Hands

There is an increasing concern for pre-designed and automatic rehabilitation technologies for elderly and stroke patients. These technologies require less human intervention and may be suited for the developing world where the supply of trained health professionals is low. However, rehabilitation through devices that assist active movements does not consider patient intention. Rehabilitation devices that take patient intention into account often use EMG signals. These signals originate from the muscles' natural drive intended to create a movement. If these devices use EMG signals in addition to pre-designed signals, various assistive activities can occur based on patient condition and experience [3]. A concurrent approach of teaching simulation tasks while training with assistive EMG-controlled robotics may improve the interaction of disruptive activities by releasing neuroactive growth factors (such as

serotonin). Such activities also create a more engaging practice for patients with moderate to severe impairments.

Active hand function is essential for manual and finger-based tasks. Rehabilitation of hand impairment is critical in brain recovery after stroke. However, current rehabilitation approaches do not train finger independence and dexterity or require highly skilled clinicians to facilitate robotic assistance. This study presents the design, fabrication, and control implementation of a novel soft robotic hand, providing a comprehensive solution to the key challenges of hand rehabilitation [15]. A soft hand prototype embeds pneumatic soft actuators with four degrees of freedom, mimicking finger joint motion, soft compliance, patient safety engagement, and a 3D-printed palm for mounting soft actuators. The development of this soft rehab hand is challenging as accurate control of soft actuators is difficult due to the nonlinear behavior of the soft materials, necessitating a specific control strategy.

6.1. Closed-Loop Control

Using real-time electro-tactile feedback to the forearm, a closed-loop control system that enables users to adjust the grasping force in a virtual prosthetic hand is developed. The system used a joystick to regulate the force rate, which was modeled as an integrator ($G(s) = 0.5/s$). Additionally, tactile feedback on grip strength was provided via electrical pulses with widths ranging from 120 to 500 microseconds, which were proportionately scaled to the applied force magnitude. Minimum lifting forces and maximum safe force thresholds comprised object-specific target force windows. Before switching to tactile-only control, individuals were exposed to visual and tactile feedback through training steps. Using feedback, the system outperformed feedforward control techniques, which obtained about 40% success in object grasping tests, with a 72% success rate. When system dynamics were changed, robust performance was maintained ($G(s) = 1/s$). The potential usefulness of electro-tactile feedback for prosthetic applications was further highlighted by observing the ability to generalize force application to unknown objects [46]. Figure 5 illustrates the trial's steps.

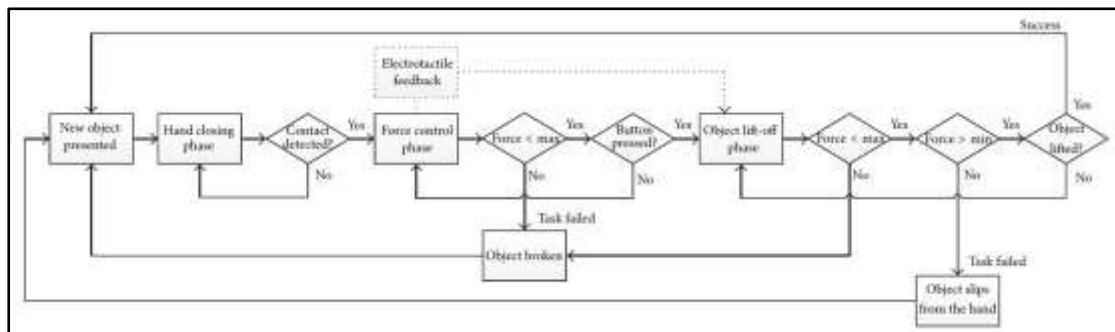

Figure 5: The procedures that make up a single virtual grasping trial. Hand closing, force control, and item lift-off were the three stages. If the object was successfully raised while maintaining the grasping force within the specified bounds (target window) for the particular object, the trial was considered successful [46].

Nonlinear hyperelastic soft materials create model uncertainty and hysteresis, which makes the gain and phase margins in closed-loop systems less stable. Most reported controllers depend on empirical tuning and lack formal bounded-input bounded-output (BIBO) assurances. This shows that there is a big gap in research on stability-certified control of soft rehabilitation devices.

6.2. Closed-Loop Control System for EMG-Driven Soft Robotic Glove

Soft gloves powered by EMG usually use feature extraction from sEMG signals and then machine learning regression or classification to figure out what the user wants. Most of the time, reported performances get R^2 values between 0.7 and 0.85 with delays of about 200 ms. To work, most EMG-based regression models need 15 to 30 minutes of subject-specific calibration data, which includes several contraction trials. Cross-user generalization is still limited, and most systems need to be retrained for new users.

6.3 Stability and Control Limitations

Most controllers don't give formal stability proofs because soft-material dynamics aren't linear. Instead, they rely on empirical tuning. There are only a few studies that talk about designs that are based on passivity or Lyapunov stability. Future endeavors must integrate stability-assured control frameworks. There are not many studies that directly test controllers when patients have problems like spasticity, tremor, or involuntary contractions. Most validations are done in controlled lab settings, which shows that there isn't enough testing for robustness in real-life rehabilitation situations.

7. Evaluation Metrics for Smart Soft Fingers Rehabilitation Hands

The following performance measures are commonly adopted in the rehabilitation assessment and experiments of smart soft fingers rehabilitation hands. The rehabilitation assessment is generally determined by the degree of restoration of injured functions in individuals, which is usually difficult to

define quantitatively. Performance measures are developed to objectively evaluate the rehabilitation, which reflects the individual restoration of functional ability. For smart soft fingers rehabilitation hands, these measures generally evaluate the rehabilitation performance of finger motion states, finger motion interactions, metacarpal states, and motion efficiency. In addition to the rehabilitation performance measures, user intent detection is also an important issue for passive rehabilitation hands (effectively responding to user voluntary finger motion intentions) and teleoperation (effectively tracking rehabilitation hand motion commands or user control signals) [3].

Motion states and interaction measures are commonly adopted for smart soft fingers rehabilitation hands with sensitized fingers. Finger motion state measures often evaluate the individual degree of restoration of the joint angle mobility of the injured finger or the thumb opposition range of movement between the thumb and other fingers. Finger motion interaction measures are often built for multi-finger rehabilitation hands. These measures usually reflect the changes of coordination in the finger motion state when fluent motions are performed in follow-up practice sessions relative to the initial practice session, which governs the shape-adjusting adaptability of the hand to the object [49]. The tactile sensor signals of finger soft skins are measured for smart soft fingers rehabilitation hands. Determining the metacarpal state measure evaluates the corresponding finger joint angles by developing a projection function, which defines the relationship between the tactile sensor signals and finger joint angles based on a radial basis function neural network.

7.1. Performance Measures

Comprehensive analysis and evaluation techniques must be predominantly integrated throughout the architectural development of smart soft fingers rehabilitation hands. An in-depth literature review attempts to outline specific performance measures and metrics furnished in existing research works. Knowledge about the available rehabilitation hand performance measures is of core significance in developing newly envisaged rehabilitation hands pursuing optimal performance metrics concerning other systems. Moreover, the utilization of optimal design paradigm performance measures can aid in minimizing the chances of production errors and safety hazards in concerned rehabilitation systems. Most tactile rehabilitation hands design and development research has overarchingly focused on technical analysis data with reiterative research goals. Thus, specific performance measures with simulations and matrix precedence to assess the capability of envisaged tactile rehabilitation hands for other tactile systems obstructively lack in the scope of cited literature review works [44].

Several paradigmatic performance measures metrics with their expected ranges that can benefit the architectural development of soft fingers rehabilitation hands are characterized. The literature review works outcast the comprehension of the overall rehabilitation hand design process, including the performance measures feasibility analysis, evaluation and design steps, and normalization approaches. Performance measures details represented by their important equations with symbols and dimension values are displayed in subsequent tables of modeling approaches. By inputting recognized and relative parameters in the concerned equations, expected values for the envisaged rehabilitation system are calculated.

7.2. Experimental Validation on Human Subjects

Of the studies reviewed, about 28% were confirmed on healthy subjects, and only 22% included patient trials, primarily involving stroke survivors. The other systems (about 50%) were only tested in a lab and not in a clinical setting. This shows that many soft robotic rehabilitation prototypes don't work well in real-world settings, and it shows that we need bigger, more patient-centered clinical studies to see how well they work, how easy they are to use, and how safe they are over time.

8. Challenges and Future Directions

Despite progress in the development of smart soft fingers rehabilitation hands, several challenges remain to be addressed. One of the main challenges is the need for improved sensor technologies that can provide more accurate and reliable information about the positioning and hand-robot interaction [15]. Additionally, the robustness of the sensor-hardware design is an important consideration, as soft fingers and hands can undergo wear and damage that may affect the performance of embedded sensors. Other important issues include the device and actuators' repeatability, modularity, safety, and user-friendliness. In addition to these challenges, there are several directions for potential future works that can create new opportunities for smart soft fingers rehabilitation hands. For instance, with the increased availability of compact sensors and electronics, soft fingers and hands may integrate more sensors, actuators, and functionalities while maintaining a compact design. Furthermore, there are opportunities for integrating machine learning algorithms into the control strategies of smart soft fingers hands to improve their performance and robustness.

8.1. Current Limitations and Areas for Improvement

Smart soft fingers rehabilitation hands have made great progress in the rehabilitation of hand disabilities, although they contain specific current limitations. Firstly, the DIY capability is limited. Most soft rehabilitation hands in literature are finished works of a specific laboratory, while many disabled patients want to build their own rehabilitation hands according to their requirements. A comprehensive design

and fabrication methodology is needed to achieve DIY so that a general design can be tailored. However, it is usually ignored in the current literature. Secondly, Scalability is limited. Different patients usually have different end-effector sizes. Most existing designs are hand-specific. To achieve scalable designs, the size of the soft fingers should be design-independent, while it is usually hand-specific in the current literature. Thirdly, the tactile sensation of the hand is limited. Soft fingers are more compliant and safer for touching objects, while practically, there are few well-designed tactile sensors integrated into the fingers. They can be embedded in soft materials or designed as sealed hollow structures to achieve tactile sensing. However, both designs may hinder the finger motion. The soft finger with variable stiffness could be a promising solution to tactile sensing, which has yet to be explored in depth.

Machine learning methods need big datasets, which usually means recording each subject for tens of minutes and going through several calibration sessions. Generalization across users is still limited. Even though technology is moving rapidly, there is no current system that can do all of these things at once: be very portable, sense in multiple ways, guarantee formal stability, and be tested on a large scale in clinical settings. The main problem in this field is still figuring out how to close this gap.

9. Conclusion and Summary

Smart soft fingers rehabilitation hand devices have fascinated researchers aiming to improve upper limb rehabilitation efficiency and safety in recent years. Devices equipped with mechanical sensors to track finger motion and applied force greatly help therapists' manipulation and rehabilitation data collection [3]. Heathered sensors to pinpoint the tactile shape of the object grasped by multi-fingered hands have shown promising applications for object identification and grasp analysis [16], [50]. A three-on-three modular symmetric soft finger grasping hand is built and controlled by onboard sensors to grasp similar objects with adjustable and repeatable force. Exploration of the design and fabrication of soft finger rehabilitation hands with embedded sensors has been summarized. A five-fingered soft hand with soft actuators and multi-sensors integrated into one finger has a compliant framework, and the finger motion can be modeled and controlled properly. The hand design and fabrication procedures are elaborated. Then, with developed sensors, the grasping force can be feedback and finger motion can be detected, which enables the hand to control the movement and force of each finger to adapt to the grasp environment. Then, force control with compliance to reduce injury risk during rehabilitation is theoretically analyzed based on sensor-applied forces. Finally, two experiments were presented to verify the performance of the smart soft fingers rehabilitation hand, including grasping similar cubes and throwing balls toward target holes.

Inspired by human soft fingers and palms, industrial and academic researchers proposed smart grasping hands. A visual-based soft robotic hand with shape memory polymer actuated compliant McKibben-like artificial muscles is designed to grasp mangoes. A palmate soft hand that can grasp objects of different shapes and sizes and use soft materials is built. An underactuated 2 DOF soft fingers lie in a straight state when unactuated, enabling the finger to automatically adjust the grasping force by the object's shape and weight without additional sensor feedback. A multi-fingered collaborative grasping approach inspired by an octopus is presented with postural adjustment to make the multi-fingered soft hand conform to the object surface. A bio-inspired integrated tendon-morphology soft hand to grip the object passively is developed. A fully soft multi-fingered hand with soft deformable elastomer fingers is realized to offer safe human-robot interaction. A soft-fingered robotic hand is proposed to grasp objects using a bi-stable electrothermal actuator embedded with low-cost thermal stretchable shape memory alloy wires.

10. References

- [1] A. Saldarriaga, E. I. Gutierrez-Velasquez, and H. A. Colorado, "Soft Hand Exoskeletons for Rehabilitation: Approaches to Design, Manufacturing Methods, and Future Prospects," Mar. 01, 2024, *Multidisciplinary Digital Publishing Institute (MDPI)*. Doi: 10.3390/robotics13030050.
- [2] T. Shahid, D. Gouwanda, S. G. Nurzaman, and A. A. Gopalai, "Moving toward soft robotics: A decade review of the design of hand exoskeletons," Sep. 01, 2018, *MDPI Multidisciplinary Digital Publishing Institute*. Doi: 10.3390/biomimetics3030017.
- [3] C. Y. Chu and R. M. Patterson, "Soft robotic devices for hand rehabilitation and assistance: A narrative review," Feb. 17, 2018, *BioMed Central Ltd*. doi: 10.1186/s12984-018-0350-6.
- [4] D. Wang *et al.*, "Soft Actuators and Robots Enabled by Additive Manufacturing," May 03, 2023, *Annual Reviews Inc*. doi: 10.1146/annurev-control-061022-012035.
- [5] Y. She, C. Li, J. Cleary, and H. J. Su, "Design and fabrication of a soft robotic hand with embedded actuators and sensors," *J Mech Robot*, vol. 7, no. 2, 2015, doi: 10.1115/1.4029497.
- [6] Q. Xie *et al.*, "Design of a SMA-based soft composite structure for wearable rehabilitation gloves," *Front Neurorobot*, vol. 17, Feb. 2023, doi: 10.3389/fnbot.2023.1047493.
- [7] X. Chen *et al.*, "A Wearable Hand Rehabilitation System with Soft Gloves," *IEEE Trans Industr Inform*, vol. 17, no. 2, pp. 943–952, Feb. 2021, doi: 10.1109/TII.2020.3010369.
- [8] D. H. Kim, S. W. Lee, and H.-S. Park, *Sensor evaluation for soft robotic hand rehabilitation devices*.
- [9] Y. Lee and H. S. Park, "Design Optimization of a Soft Robotic Rehabilitation Glove Based on Finger Workspace Analysis," *Biomimetics*, vol. 9, no. 3, Mar. 2024, doi: 10.3390/biomimetics9030172.

- [10] W. Thimabut, P. Terachinda, and W. Kitisomprayoonkul, "Effectiveness of a Soft Robotic Glove to Assist Hand Function in Stroke Patients: A Cross-Sectional Pilot Study," *Rehabil Res Pract*, vol. 2022, 2022, doi: 10.1155/2022/3738219.
- [11] D. Hu, J. Zhang, Y. Yang, Q. Li, D. Li, and J. Hong, "A novel soft robotic glove with positive-negative pneumatic actuator for hand rehabilitation," in *IEEE/ASME International Conference on Advanced Intelligent Mechatronics, AIM*, Institute of Electrical and Electronics Engineers Inc., Jul. 2020, pp. 1840–1847. doi: 10.1109/AIM43001.2020.9158826.
- [12] O. Ozioko and R. Dahiya, "Smart Tactile Gloves for Haptic Interaction, Communication, and Rehabilitation," *Advanced Intelligent Systems*, vol. 4, no. 2, Feb. 2022, doi: 10.1002/aisy.202100091.
- [13] Y. Ahmed, A. Al-Neami, and S. Lateef, "Robotic Glove for Rehabilitation Purpose: Review," *Iraqi Journal for Electrical and Electronic Engineering*, vol. sceeer, no. 3d, pp. 86–92, Jul. 2020, doi: 10.37917/ijeee.sceeer.3rd.12.
- [14] Z. Yue, X. Zhang, and J. Wang, "Hand Rehabilitation Robotics on Poststroke Motor Recovery," 2017, *Hindawi Limited*. Doi: 10.1155/2017/3908135.
- [15] S. Alves, M. Babcinski, A. Silva, D. Neto, D. Fonseca, and P. Neto, "Integrated Design Fabrication and Control of a Bioinspired Multimaterial Soft Robotic Hand," *Cyborg and Bionic Systems*, vol. 4, 2023, doi: 10.34133/cbsystems.0051.
- [16] Y. Zhu, W. Gong, K. Chu, X. Wang, Z. Hu, and H. Su, "A Novel Wearable Soft Glove for Hand Rehabilitation and Assistive Grasping," *Sensors*, vol. 22, no. 16, Aug. 2022, doi: 10.3390/s22166294.
- [17] Y. Lee and H. S. Park, "Design Optimization of a Soft Robotic Rehabilitation Glove Based on Finger Workspace Analysis," *Biomimetics*, vol. 9, no. 3, Mar. 2024, doi: 10.3390/biomimetics9030172.
- [18] S. M. Lee and J. Park, "A soft wearable exoglove for rehabilitation assistance: a novel application of knitted shape-memory alloy as a flexible actuator," *Fashion and Textiles*, vol. 11, no. 1, Dec. 2024, doi: 10.1186/s40691-024-00377-9.
- [19] J. Lai, A. Song, K. Shi, Q. Ji, Y. Lu, and H. Li, "Design and Evaluation of a Bidirectional Soft Glove for Hand Rehabilitation-Assistance Tasks," *IEEE Trans Med Robot Bionics*, vol. 5, no. 3, pp. 730–740, Aug. 2023, doi: 10.1109/TMRB.2023.3292414.
- [20] T. Aghil, S. Rahul, S. Buvan Kumar, Y. Vijay, S. Tharun Kumar, and B. Sidharth, "A Futuristic Approach for Stroke Rehabilitation Using Smart Gloves," in *Journal of Physics: Conference Series*, IOP Publishing Ltd, Nov. 2021. doi: 10.1088/1742-6596/2115/1/012025.
- [21] Panagiotis Polygerinos, "soft robotic love for hand rehabilitation."
- [22] Z. Sheng Sun, Z. Hua Guo, and W. Tang, "Design of wearable hand rehabilitation glove with soft hoop-reinforced pneumatic actuator," *J Cent South Univ*, vol. 26, no. 1, pp. 106–119, Jan. 2019, doi: 10.1007/s11771-019-3986-x.
- [23] Y. Han, Q. Xu, and F. Wu, "Design of Wearable Hand Rehabilitation Glove With Bionic Fiber-Reinforced Actuator," *IEEE J Transl Eng Health Med*, vol. 10, 2022, doi: 10.1109/JTEHM.2022.3196491.
- [24] A. Arivarasi et al., "An advanced cost-efficient IoT method for stroke rehabilitation using smart gloves," *Nanotechnology and Precision Engineering*, vol. 6, no. 4, Dec. 2023, doi: 10.1063/10.0020290.
- [25] H. K. Yap, J. H. Lim, J. C. H. Goh, and C. H. Yeow, "Design of a soft robotic glove for hand rehabilitation of stroke patients with clenched fist deformity using inflatable plastic actuators," *Journal of Medical Devices, Transactions of the ASME*, vol. 10, no. 4, Dec. 2016, doi: 10.1115/1.4033035.
- [26] Y. Wang, T. Hao, Y. Liu, H. Xiao, S. Liu, and H. Zhu, "Anthropomorphic Soft Hand: Dexterity, Sensing, and Machine Learning," Mar. 01, 2024, *Multidisciplinary Digital Publishing Institute (MDPI)*. Doi: 10.3390/act13030084.
- [27] M. Tavakoli, A. Sayuk, J. Lourenço, and P. Neto, "Anthropomorphic finger for grasping applications: 3D printed endoskeleton in a soft skin," *International Journal of Advanced Manufacturing Technology*, vol. 91, no. 5–8, pp. 2607–2620, Jul. 2017, doi: 10.1007/s00170-016-9971-8.
- [28] Y. Huang et al., "Human-like dexterous manipulation for anthropomorphic five-fingered hands: A review," Mar. 01, 2025, *Elsevier B.V.* doi: 10.1016/j.birob.2025.100212.
- [29] A. Bardo et al., "The Precision of the Human Hand: Variability in Pinch Strength and Manual Dexterity," 2022, doi: 10.3390/sym.
- [30] B. Gherman et al., "Robotic Systems for Hand Rehabilitation—Past, Present and Future," Jan. 01, 2025, *Multidisciplinary Digital Publishing Institute (MDPI)*. Doi: 10.3390/technologies13010037.
- [31] J. Xu et al., "A rehabilitation robot control framework with an adaptation of training tasks and robotic assistance," *Front Bioeng Biotechnol*, vol. 11, 2023, doi: 10.3389/fbioe.2023.1244550.
- [32] S. Zhou, Y. Li, Q. Wang, and Z. Lyu, "Integrated Actuation and Sensing: Toward Intelligent Soft Robots," Jan. 01, 2024, *American Association for the Advancement of Science*. Doi: 10.34133/cbsystems.0105.
- [33] Z. Zhang, A. D. Calderon, X. Huang, G. Wu, and C. Liang, "Design and Driving Performance Study of Soft Actuators for Hand Rehabilitation Training," *Medical Devices: Evidence and Research*, vol. 17, pp. 237–260, 2024, doi: 10.2147/MDER.S476464.
- [34] K. H. L. Heung, H. Li, T. W. L. Wong, and S. S. M. Ng, "Assistive robotic hand with bi-directional soft actuator for hand impaired patients," *Front Bioeng Biotechnol*, vol. 11, 2023, doi: 10.3389/fbioe.2023.1188996.
- [35] M. Pan et al., "Soft Actuators and Robotic Devices for Rehabilitation and Assistance," *Advanced Intelligent Systems*, vol. 4, no. 4, Apr. 2022, doi: 10.1002/aisy.202100140.

- [36] P. Weiner, C. Neef, Y. Shibata, Y. Nakamura, and T. Asfour, "An embedded, multi-modal sensor system for scalable robotic and prosthetic hand fingers," *Sensors (Switzerland)*, vol. 20, no. 1, Jan. 2020, doi: 10.3390/s20010101.
- [37] T. Wu, H. Deng, Z. Sun, X. Zhang, C. Lee, and X. Zhang, "Intelligent soft robotic fingers with multi-modality perception ability," *iScience*, vol. 26, no. 8, Aug. 2023, doi: 10.1016/j.isci.2023.107249.
- [38] H. Bayoumi, M. I. Awad, and S. A. Maged, "An Improved Approach for Grasp Force Sensing and Control of Upper Limb Soft Robotic Prosthetics," *Micromachines (Basel)*, vol. 14, no. 3, Mar. 2023, doi: 10.3390/mi14030596.
- [39] J. Godoy Da Silva, A. Augusto De Carvalho, and D. Dutra Da Silva, "A Strain Gauge Tactile Sensor for Finger-Mounted Applications," 2002. [Online]. Available: <http://www.dee.feis.unesp.br>
- [40] M. J. Ko, Y. C. Chuang, L. J. Ou-Yang, Y. Y. Cheng, Y. L. Tsai, and Y. C. Lee, "The Application of Soft Robotic Gloves in Stroke Patients: A Systematic Review and Meta-Analysis of Randomized Controlled Trials," Jun. 01, 2023, *MDPI*. doi: 10.3390/brainsci13060900.
- [41] S. Zhao *et al.*, "3D-Printed Soft Pneumatic Robotic Digit Based on Parametric Kinematic Model for Finger Action Mimicking," *Polymers (Basel)*, vol. 14, no. 14, Jul. 2022, doi: 10.3390/polym14142786.
- [42] S. Alves, M. Babcinski, A. Silva, D. Neto, D. Fonseca, and P. Neto, "Integrated Design Fabrication and Control of a Bioinspired Multimaterial Soft Robotic Hand," *Cyborg and Bionic Systems*, vol. 4, 2023, doi: 10.34133/cbsystems.0051.
- [43] Y. M. Zhou *et al.*, "Highlighted sensors and a passive component with integration details illustrated in an integrated glove."
- [44] A. L. Ratschat, R. Martín-Rodríguez, Y. Vardar, G. M. Ribbers, and L. Marchal-Crespo, "Design and evaluation of a multi-finger skin-stretch tactile interface for hand rehabilitation robots," Feb. 2024, [Online]. Available: <http://arxiv.org/abs/2402.12060>
- [45] N. Zhang *et al.*, "Soft robotic hand with tactile palm-finger coordination," *Nature Communications*, vol. 16, no. 1, Dec. 2025, doi: 10.1038/s41467-025-57741-6.
- [46] N. Jorgovanovic, S. Dosen, D. J. Djovic, G. Krajoski, and D. Farina, "Virtual grasping: Closed-loop force control using electrotactile feedback," *Comput Math Methods Med*, vol. 2014, 2014, doi: 10.1155/2014/120357.
- [47] M. Sierotowicz *et al.*, "EMG-Driven Machine Learning Control of a Soft Glove for Grasping Assistance and Rehabilitation," *IEEE Robot Autom Lett*, vol. 7, no. 2, pp. 1566–1573, Apr. 2022, doi: 10.1109/LRA.2021.3140055.
- [48] L. Cheng, M. Chen, and Z. Li, "Design and Control of a Wearable Hand Rehabilitation Robot," *IEEE Access*, vol. 6, pp. 74039–74050, 2018, doi: 10.1109/ACCESS.2018.2884451.
- [49] P. Capsi-Morales *et al.*, "Comparison between rigid and soft poly-articulated prosthetic hands in non-expert myoelectric users shows advantages of soft robotics," *Sci Rep*, vol. 11, no. 1, Dec. 2021, doi: 10.1038/s41598-021-02562-y.
- [50] R. Rätz, F. Conti, R. M. Müri, and L. Marchal-Crespo, "A Novel Clinical-Driven Design for Robotic Hand Rehabilitation: Combining Sensory Training, Effortless Setup, and Large Range of Motion in a Palmar Device," *Front Neurobotics*, vol. 15, Dec. 2021, doi: 10.3389/fnbot.2021.748196.